

# **screentech**<sup>TM</sup> LED Flood Lights

POWER SAVING REPLACEMENT ALTERNATIVE  
TO HALOGEN FLOOD LIGHTS

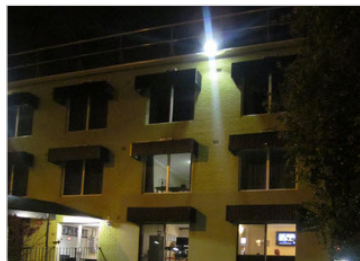

**THE SCREENTECH FLOOD LIGHTS USE ONLY THE HIGHEST QUALITY LED CHIPS, HAVE A LIFE EXPECTANCY OF OVER 50,000 HOURS AND COME WITH A 2 YEAR WARRANTY**



## FEATURES INCLUDE:

- Available in Cool White
- Available sizes: 40W, 100W, 250W
- Premium quality LED chips
- All aluminium construction with polycarbonate cover
- IP65 Protection rating
- Eco friendly - Fully recyclable
- 50,000 hour life expectancy
- 2-year warranty
- Uses 80% less power consumption compared to a halogen flood light with comparable brightness



**emotiveearth**

Emotive Earth is a major national distributor of Screentech LED Tubes. For more information or to order, contact:

**ORDER HOTLINE:** 1300 774 267 **EMAIL:** [info@emotiveearth.com.au](mailto:info@emotiveearth.com.au)

[www.emotiveearth.com.au](http://www.emotiveearth.com.au)

## SPECIFICATIONS:



40W LED Flood Light



100W LED Flood Light



250W LED Flood Light

Model	FL-040CMD	FL-100CMD	FL-250CMD
Colour Range	Cool White	Cool White	Cool White
Colour Temperature	5000 K	5000 K	5000 K
Light Source	5W high intensity LED	10W high intensity LED	30W high intensity LED
LED Quantity	8	9	8
Beam Angle	90°	90°	90°
Key Material	Aluminium Alloy + PC Lens	Aluminium Alloy + PC Lens	Aluminium Alloy + PC Lens
Power Requirement	AC 100~240V	AC 100~240V	AC 100~240V
Power Consumption	40W	100W	250W
Protection Rating	IP65	IP65	IP65
Certificate	CE	CE	CE
Operation Temperature	-25°C ~ +45°C	-25°C ~ +45°C	-25°C ~ +45°C
Dimension (mm)	L250 x W180 x D100	L320 x W300 x D168	L400 x W300 x D200
Warranty	2 years	2 years	2 years
Output Equivalent	250W Halogen/Metal Halide	500W Halogen/ 400W Metal Halide	500W+ Hi Pressure Sodium/Metal Halide

## DIMENSIONS:

40W LED Flood Light

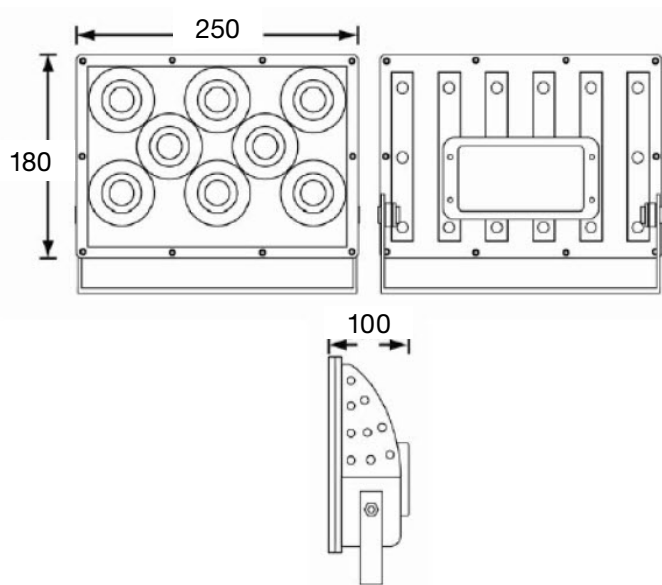

100W LED Flood Light

